



**MIL-C-22992, Class L
Installation Instructions**

Complete installation instructions (L-1014) for Class L connectors are available upon request. Reproduced below are condensed assembly instructions to familiarize the user with the installation procedure and tooling required.

Complete Preparation (RT90556 and RT90557 connectors only)

The following table shows the standard wire color coding, generator terminal markings, and connector contact identification used with Class L connectors.

Standardized Generator Wiring and Connections

Generator Terminal Marking	Current	Contact Designation	Conductor Circuit	Wire Color
+ (POS)	28Vdc	A	Positive	Black
- (NEG) ground	28Vdc	N	Negative	White
L ₁	AC	A	Phase A	Black
L ₂	AC	B	Phase B	Red
L ₃	AC	C	Phase C	Blue (commercial may be orange)
L ₀	AC	N	Neutral	White
G (or gnd)	AC	G	Safety grounding	Green (commercial may be bare)

Step 1) Determine cable lay to facilitate alignment of contacts and insert holes without wire crossing.

Step 2) Strip cable jacket to dimension shown. Avoid cutting or nicking individual conductor insulation.

Connector Size	D Inches Approx.
28	3.000
32	3.000
44	4.250
52	5.000

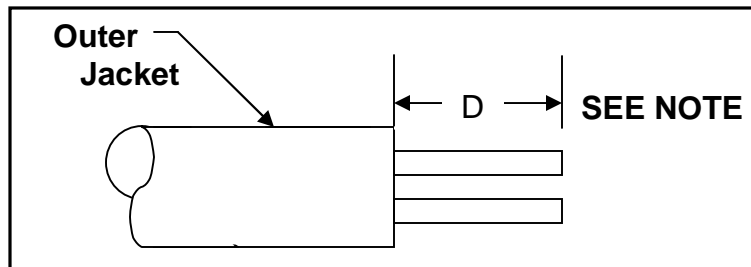

Some insert arrangements require that two or more ground wires be terminated into one contact. Dimension D must therefore be increased to permit routing these wires around the larger conductors

Step 3) Install connector components in the order shown in the applicable assembly view illustrated on following pages.

Step 4) Strip insulation of individual conductors to 3/4 inch from end of conductor.

RT90555 Connector

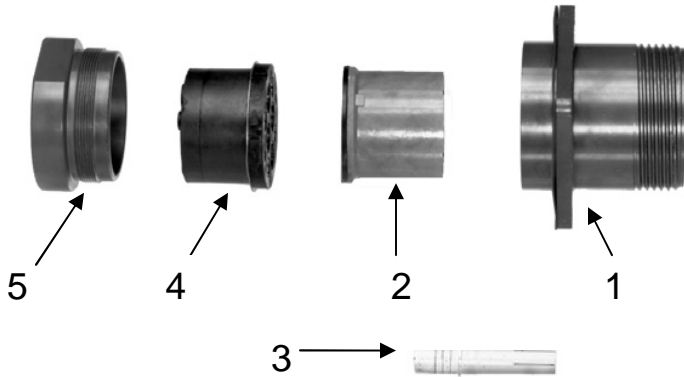

1. Shell
2. Insert Assembly, Socket
3. Contact, Socket
4. Grommet Assembly, Socket
5. Nut Retaining
6. Protective Cap Assembly (Not Shown)
7. Flange Gasket (Not Shown)

RT90556 Connector

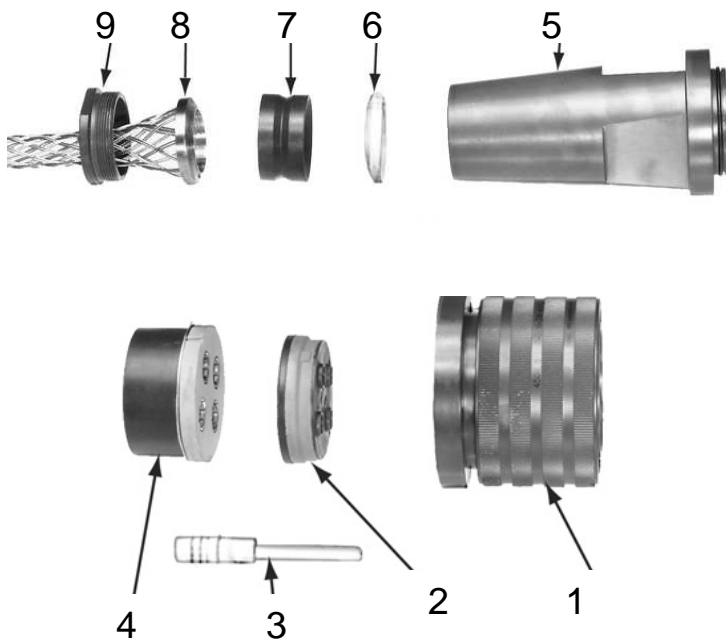

1. Shell
2. Insert Assembly, Socket
3. Contact, Socket
4. Spacer Assembly, Socket
5. Back Adapter
6. Gland Washer
7. Gland
8. Cable Grip
9. Gland Nut
10. Lockwasher (3 each)
11. Screw (3 each)
12. Protective Cap Assembly (Not Shown)

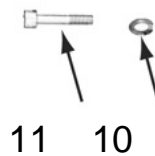

RT90557 Connector

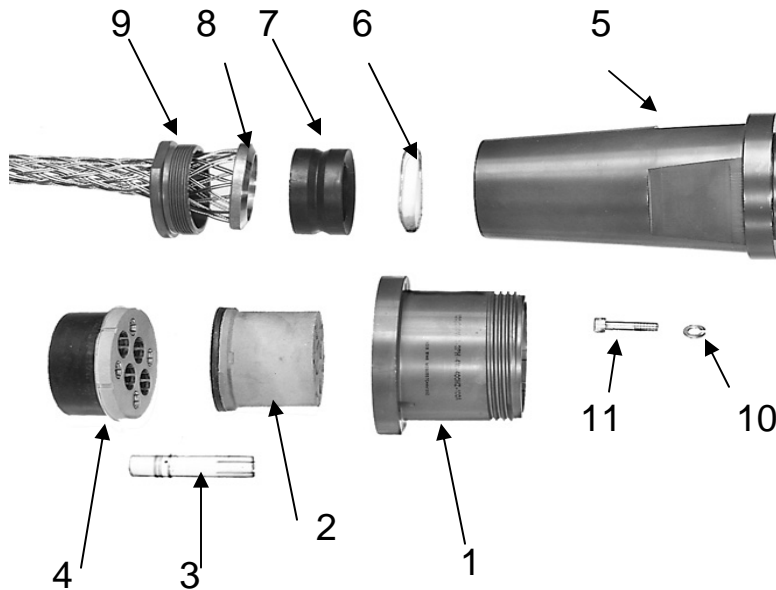

- | |
|---|
| 1. Shell |
| 2. Insert Assembly, Socket |
| 3. Contact, Socket |
| 4. Spacer Assembly, Socket |
| 5. Back Adapter |
| 6. Gland Washer |
| 7. Gland |
| 8. Cable Grip |
| 9. Gland Nut |
| 10. Lockwasher (3 each) |
| 11. Screw (3 each) |
| 12. Protective Cap Assembly (Not Shown) |

RT90558 Connector

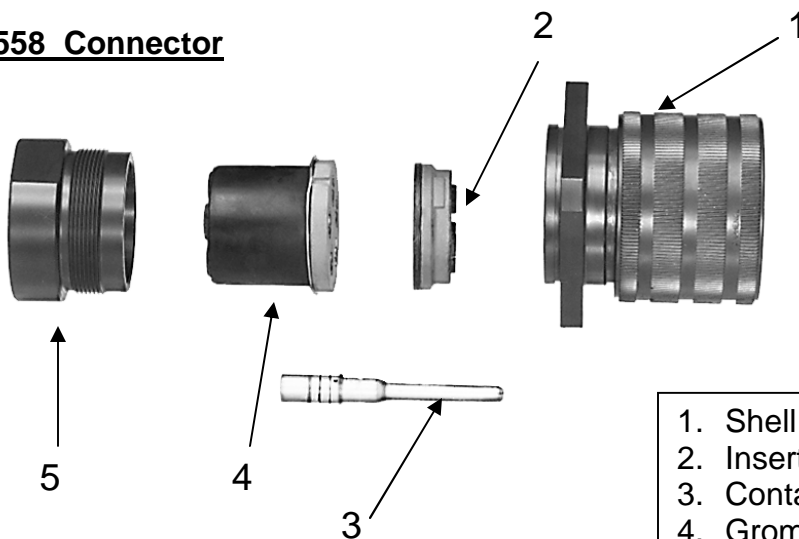

- | |
|--|
| 1. Shell and Coupling Nut Assembly |
| 2. Insert Assembly, Pin |
| 3. Contact, Pin |
| 4. Grommet Assembly, Pin |
| 5. Nut Retaining |
| 6. Protective Cap Assembly (Not Shown) |
| 7. Flange Gasket (Not Shown) |



Contact Installation

Step 1) Insert stripped conductors in contact wirewells. If contact bushing is used, insert conductor in bushing and bushing in contact wirewell. If two or more ground wires are inserted into a single contact, make sure all wires are fully seated in wirewell.

Step 2) Select correct crimping tool, locator and die combination from the table for contacts to be installed. With conductor or contact bushing in place, insert contact into tool. Close crimping die fully to form a uniform crimp.

Contact Part Number	Size	Type	Crimping Tool	Locator	Die	Removal Tool
M30020/48-327	4/0	P	Pico Model			
M39029/49-335	4/0	S	400B or	4297-1	414DA-4/0N-1	RT90562-1
M39029/48-328	4/0N	P	400B-1			
M39029/48-323	1/0	P	Pico Model			
M39029/49-333	1/0	S	400B or	4297-3	414DA-1/0N	RT90562-3
M39029/48-324	1/0N	P	400B-1			
M39029/48-320	4	P				
M39029/49-331	4	S	Pico Model			
M39029/48-321	4N	P	400B or	4297-5	414DA-4N	RT90562-5
M39029/48-322	4G	P	400B-1			
M39029/49-332	4G	S				
M39029/48-317	6	P				
M39029/49-329	6	S	Pico Model			
M39029/48-318	6N	P	400B or	4297-6	414DA-6N	RT90562-6
M39029/48-319	6G	P	400B-1			
M39029/49-330	6G	S				

If crimping tools are not available, contacts may be affixed to conductors by soldering. Use rosin- alcohol solder flux, a good grade of 60/40 solder and a 500 watt soldering iron or probe type resistance soldering equipment. Pre-tin conductors before soldering. Solder must not be present on shoulder or retention area of contact.



Connector Assembly

Step 1) If insert is not already positioned in the connector shell, align large tab on insert with large slot in shell and push insert in until it bottoms in shell.

Step 2) Apply a thin coating of Dow Corning DC-4 lubricant, or similar, to the periphery of contact holes in spacer or grommet assembly. Push contacts into rear of spacer or grommet assembly until locked into contact retainer bushing.

Step 3) Align contacts with proper holes in insert. Small key of insert must be aligned with appropriate keyway in spacer or grommet assembly. Slide contacts into insert holes until spacer or grommet assembly butts against insert. A thin film of Dow Corning DC-4 lubricant, or similar, applied to the periphery of insert contact holes will provide maximum sealing efficiency.

Step 4) Assemble accessories to connector. The back adapter “O” ring should have a very thin film of Dow Corning DC-4 lubricant, or similar, applied. Outer surfaces only of gland should be lubricated with a thin film of UniTemp Grease EP, or similar. Avoid getting grease on inside surfaces of gland and on cable jacket.

Step 5) Tighten retaining nut or gland nut on shell or adaptor. A metal- to- metal seating condition is desirable, but may not be attainable with maximum cable diameters.

Contact Removal

Step 1) Loosen all rear accessories and slide back along cable.

Step 2) Remove spacer or grommet assembly with contacts from connector insert.

Step 3) Using the appropriate size contact removal tool, push tool over front of contact until it bottoms in spacer or grommet assembly hole. This will open contact retaining bushing and allow contact to be removed from the spacer or grommet assembly from the rear. When using jacketed cable, all contacts should be released from contact retention bushings before removal from spacer or grommet assembly is accomplished.